

(Step 2 Continued)

- and fixture loop. Use supplied wire nuts to make all wire connections (Refer to WIRE CONNECTIONS A and B). Twist connectors until wires are tightly joined together. Wrap each connection with approved electrical tape.
- B. Thread one end of the nipple into the coupling on the plate with coupling. Place one cover, one crystal cover and one cap over the end of the nipple and secure with one finial. Hand tighten until snug.
- C. Thread the hex nut end of the nipple with hex nut into the hex coupling on the plate with socket. By using pliers, thread the hex nut against the hex coupling and hand tighten until snug. Place another cover, crystal cover and cap over the end of the nipple with hex nut. Secure them with another finial and hand tighten until snug.
- D. Thread the fixture loop onto the top center of the plate with coupling and hand tighten until snug.

STEP 3 - Install the Crossbar to the Ceiling

- A. Place the crossbar to the ceiling and make (4) marks from the holes of the crossbar on the ceiling for anchors. Remove the crossbar and drill proper holes from the (4) marks for anchors.
- B. Insert anchors into drilled holes properly. Place the crossbar, flat washers and spring washers onto the anchors and secure with hex nuts. Hand tighten until snug with pliers.

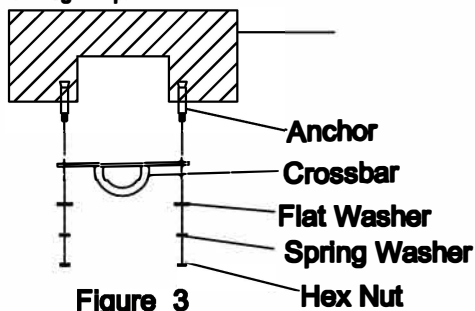

Figure 3

STEP 4 - Install Chain System and Fixture Body together

- A. Remove the bolt from the quick connector. Place the quick connector onto the chain link of the bottom end of the chain system.
- B. Place the fixture loop inside of the quick connector. Thread the bolt back onto the quick connector and the fixture loop. Hand tighten until snug to connector the chain system to the fixture.

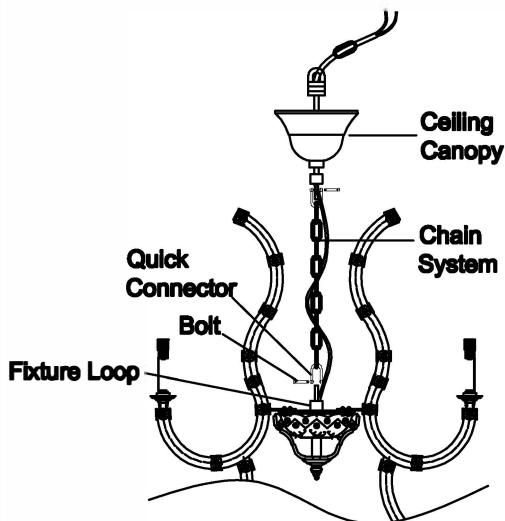

Figure 4

STEP 5 - Install Fixture to Crossbar

- A. Remove the bolt from the quick connector. Place the quick connector onto the hook of the crossbar.
- B. Insert the loop on the top end of the chain system inside of the quick connector. Thread the bolt back onto the quick connector and through the loop of the chain system. Hand tighten until snug to hang the fixture safely.
- C. Refer to Step 6 for wire connection instructions.
- D. Lift the ceiling canopy upward, over the crossbar, attach onto the ceiling. Using screwdriver, thread set screw on the ceiling canopy until snug to secure the ceiling canopy.

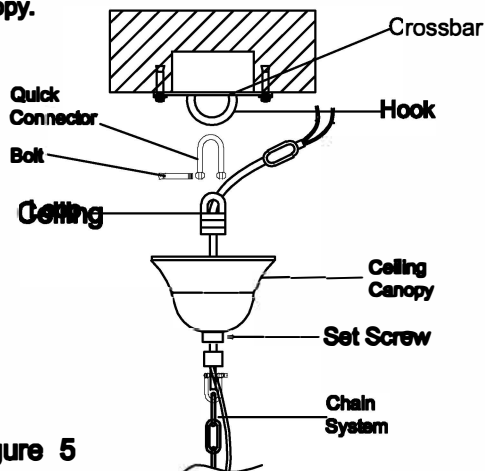

Figure 5

STEP 6 - Making the Wire Connections

- A. Use standard wire connectors (not included) to make all wire connections. Twist connectors until wires are tightly joined together. Wrap each connection with approved electrical tape and carefully stuff all the connected wires into outlet box.

Note: If the electrical wire is going to be cut shorter than provided you will need to identify the "L" line wire and the "N" neutral wire before you cut the excess wire off. One is labeled N and the other labeled L. To do this separate the "L" line wire and the "N" neutral wire as far as you need to. Re-label the wire near where you want to make the cut. Be sure to mark the wire on the side of the fixture and not on the excess wire being cut and removed.

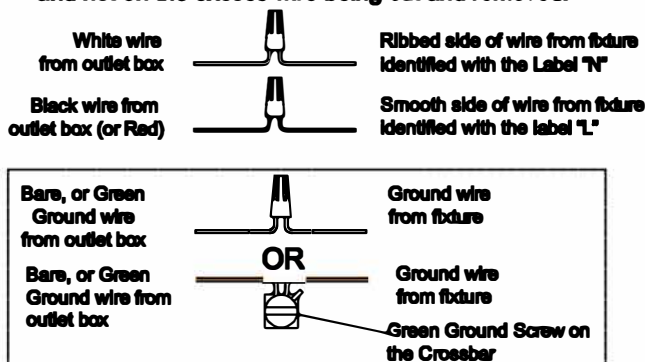

Figure 6