

Trade Mark:
CRYSTAL WORLD INC

Product Name: Pendant lamp

Model :8001C10C

120Vac, 60Hz,AC ONLY

Lamp Size:φ10"*H7"

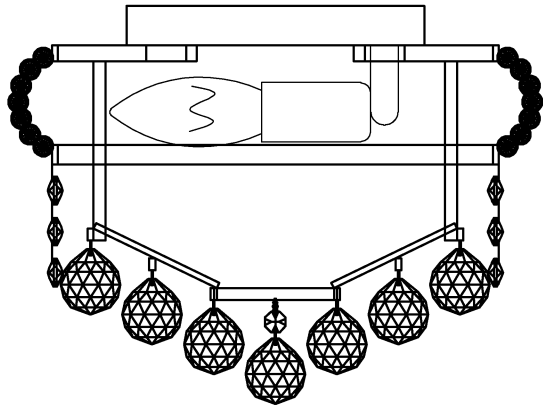

PENDANT LAMP ASSEMBLY INSTRUCTIONS

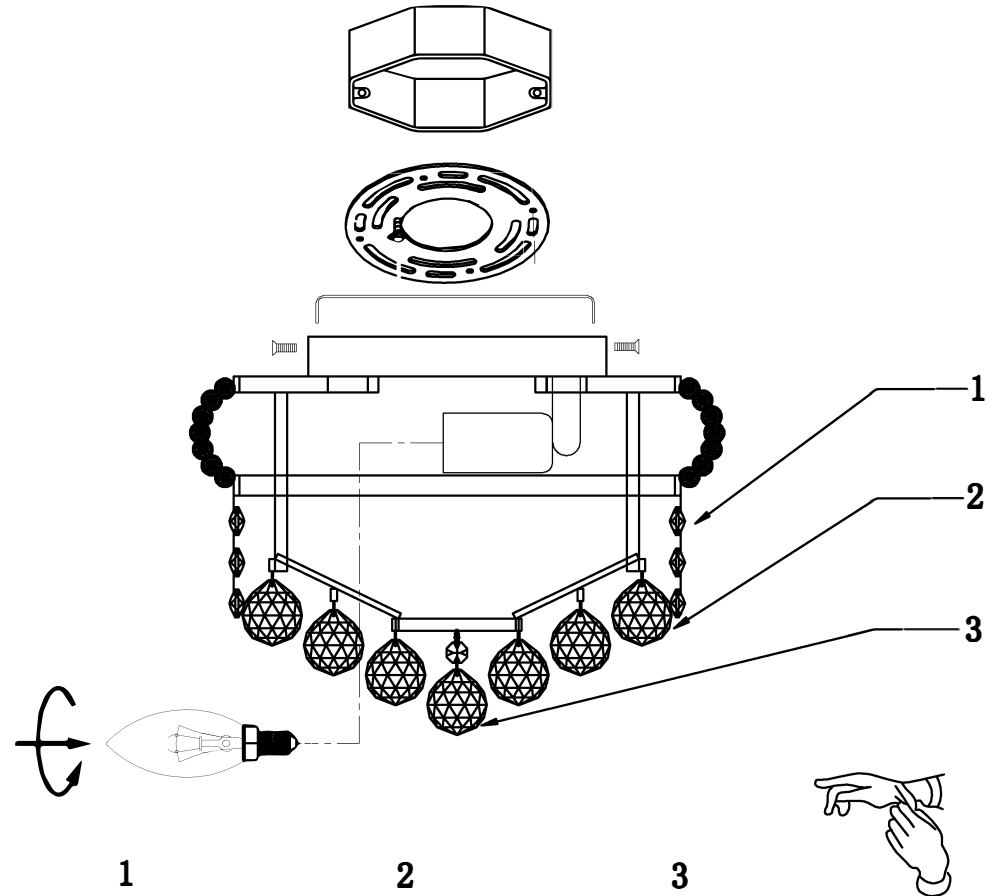

1. Please take off the plastic sheet from the lamp body.
2. Please wear gloves when you hanging the crystal.
3. Install bulbs (NOT INCLUDED).USE **120V E12**  **3*40W Max.**



1

14mm*3pcs
42PCS

2

30mm*1pcs
36PCS

3

12mm*1pcs

30mm*1pcs
1PCS