

Trade Mark:
CRYSTAL WORLD INC

Product Name: Wall lamp
Model :5465W14DB-2
120Vac, 60Hz,AC ONLY
Lamp Size:W14"*H14"*E8"

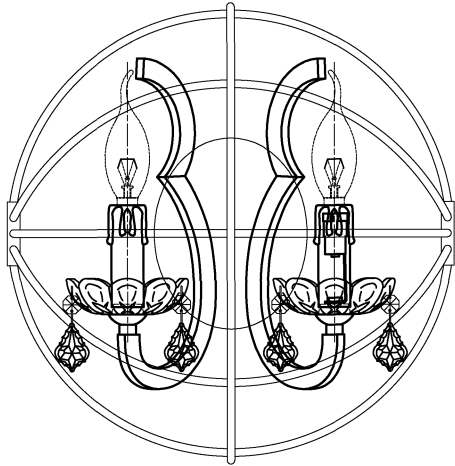

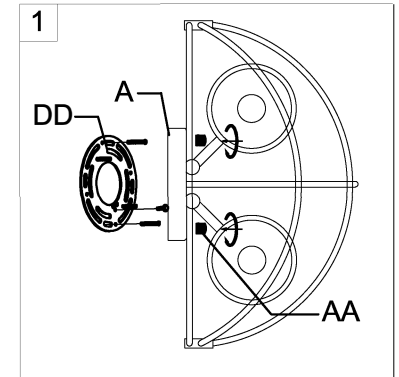

WALL LAMP ASSEMBLY INSTRUCTIONS

1. Place fixture(A) onto mounting screws (DD). Secure with cap nuts (AA).



Hardware Used

DD Mounting screw 
AA Cap nut 

2. Please fix(B) with (A) .

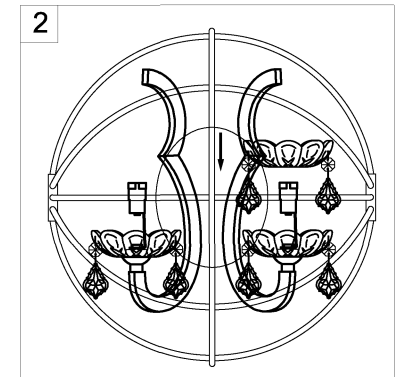
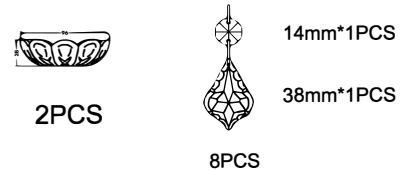

3. Install bulbs (NOT INCLUDED).
USE
120V E12 2*60W Max.

