

Trade Mark:
CRYSTAL WORLD INC

Product Name: Pendant lamp
Model :5209P5SN
120Vac, 60Hz,AC ONLY
Lamp size:Ø5"XH26"~75"

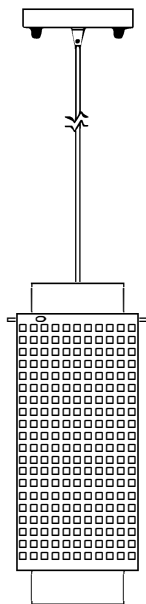

PENDANT LAMP ASSEMBLY INSTRUCTIONS

1. Place fixture(A) onto mounting screws (DD). secure with cap nuts (AA).

Hardware Used

AA Cap nut		X 2
DD Mounting screw		X 2

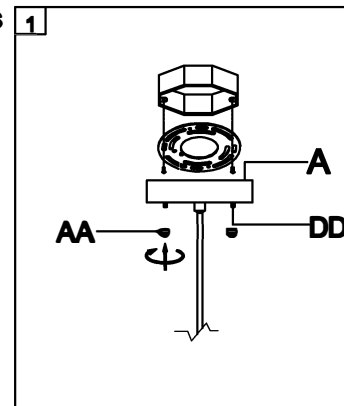

2. Please with iron bars will be (B) (C) on the (A)

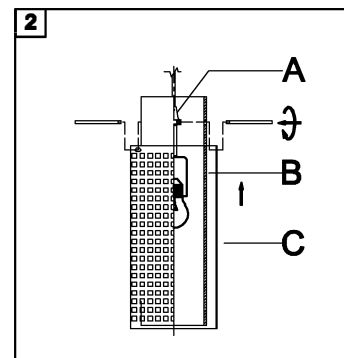
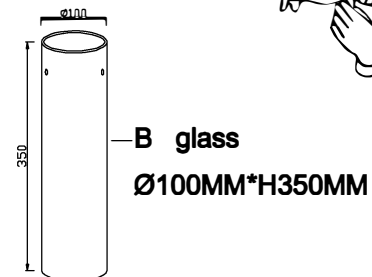

3. Install light bulbs (not included).
Use bulb
120V E26  1*60W Max.

